



UNIVERSITY OF CAMBRIDGE INTERNATIONAL EXAMINATIONS
General Certificate of Education Ordinary Level

CANDIDATE
NAME

CENTRE
NUMBER

--	--	--	--	--

CANDIDATE
NUMBER

--	--	--	--



PHYSICS

5054/41

Paper 4 Alternative to Practical

May/June 2011

1 hour

Candidates answer on the Question Paper.

No Additional Materials are required.

READ THESE INSTRUCTIONS FIRST

Write your Centre number, candidate number and name on all the work you hand in.

Write in dark blue or black pen.

You may use a soft pencil for any diagrams, graphs or rough working.

Do not use staples, paper clips, highlighters, glue or correction fluid.

DO NOT WRITE IN ANY BARCODES.

Answer **all** questions.

You may lose marks if you do not show your working or if you do not use appropriate units.

At the end of the examination, fasten all your work securely together.

The number of marks is given in brackets [] at the end of each question or part question.

This document consists of **11** printed pages and **1** blank page.



- 1 A student investigates the behaviour of a capacitor as it is charged.

The student connects a capacitor C and a resistor R in series with an ammeter and a d.c. power supply, as shown in Fig. 1.1.

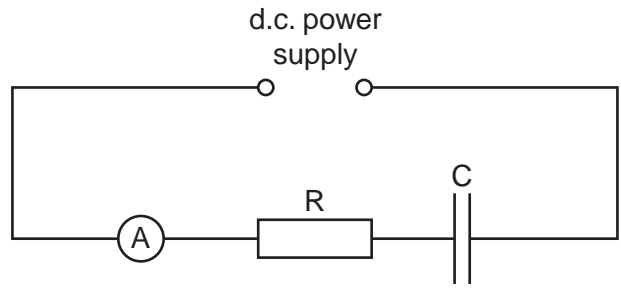

Fig. 1.1

- (a) The student notices that the reading on the ammeter decreases to zero.

- (i) Explain why there is no current in the circuit after some time.

.....
[1]

- (ii) The student disconnects the circuit using a movable lead, as shown in Fig. 1.2.

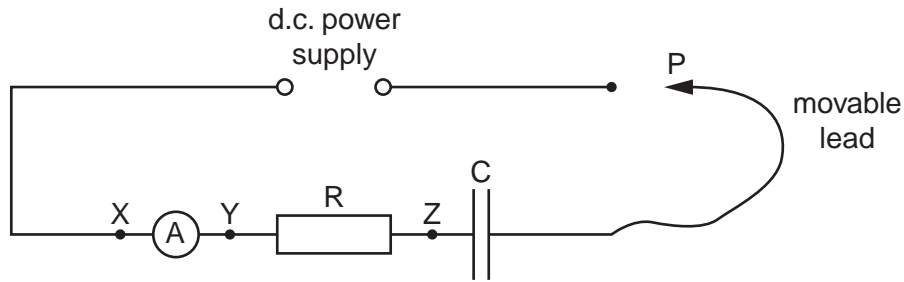

Fig. 1.2

In order to discharge the capacitor, the student may connect the end P of the movable lead to either point X, Y or Z.

State and explain which connection will discharge the capacitor the fastest.

.....
[1]

- (b) The capacitor is now fully discharged.

The student reconnects the circuit of Fig. 1.1 and observes the initial ammeter reading. The ammeter is shown in Fig. 1.3.

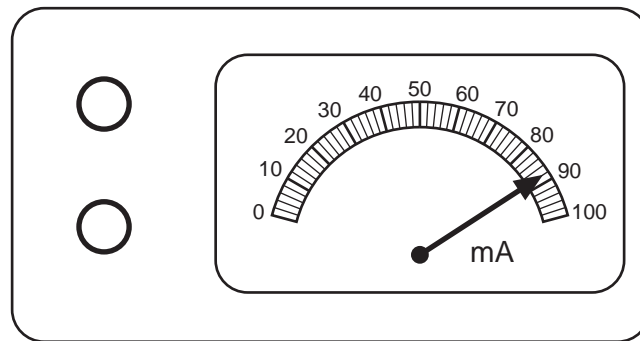

Fig. 1.3

State the reading on the ammeter.

ammeter reading =[1]

- (c) The student observes the needle as the current in the ammeter begins to fall and starts timing when the current is 80 mA.

The time t for the current to fall from 80 mA to a value I is measured. Readings of current I and time t are shown in Fig. 1.4.

I/mA	t/s
80	0
60	6.33
40	15.25
30	21.58
20	30.50
10	45.75
5	61.00

Fig. 1.4

- (i) On Fig. 1.5, plot the graph of I /mA on the y -axis against t /s on the x -axis. Draw the curved line of best fit.

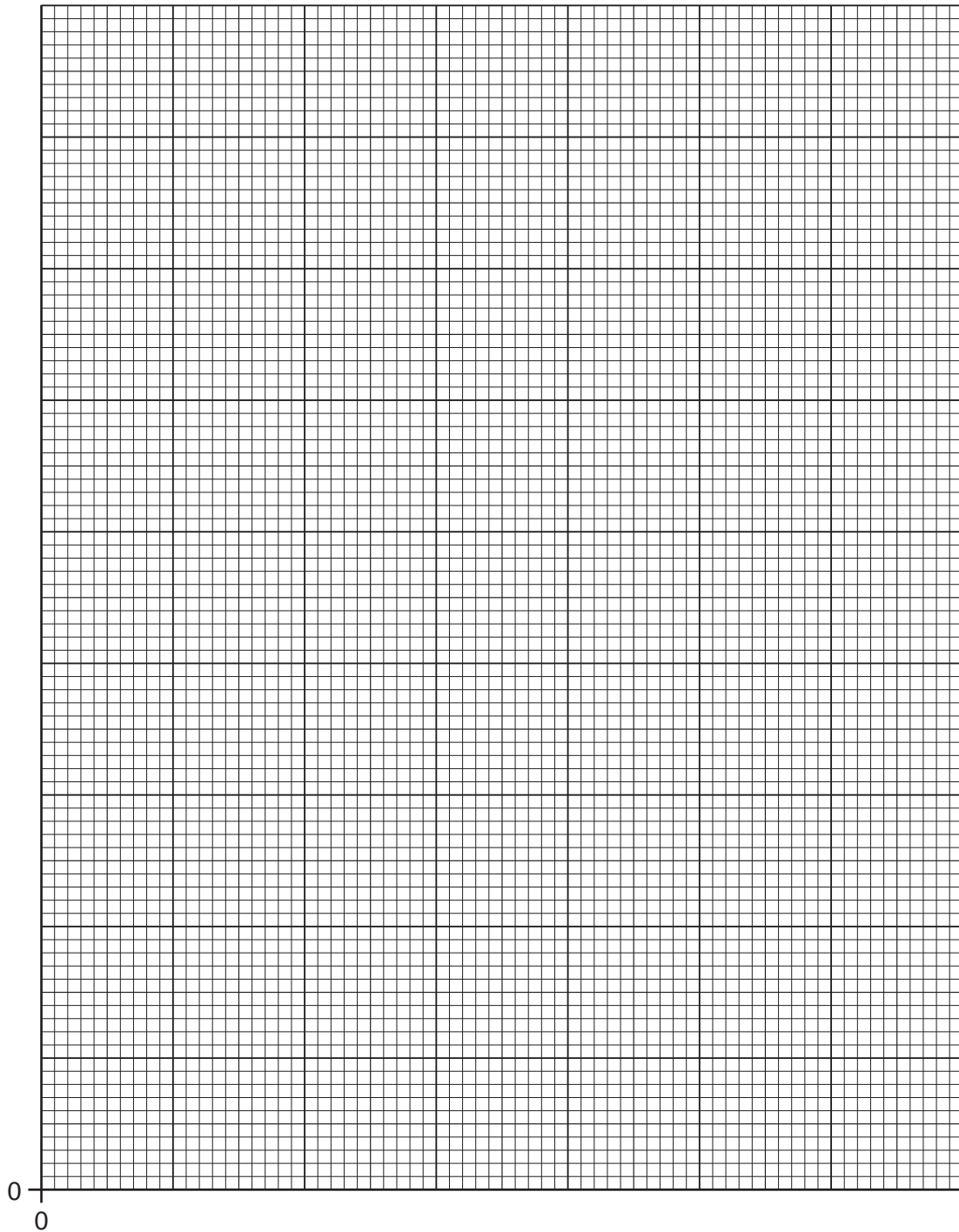

Fig. 1.5

[4]

(ii) Use your graph to describe the relationship between I and t .

.....
.....[1]

(iii) The resistance of resistor R is 100Ω .

Use your graph to find the potential difference V across the resistor at time $t = 40\text{ s}$.
You may use the relationship $V = IR$.

$V =$ [2]

2 A displacement can is a container with a spout, used to determine the volume of an object.

Fig. 2.1 shows a displacement can and a cross-section of the can.

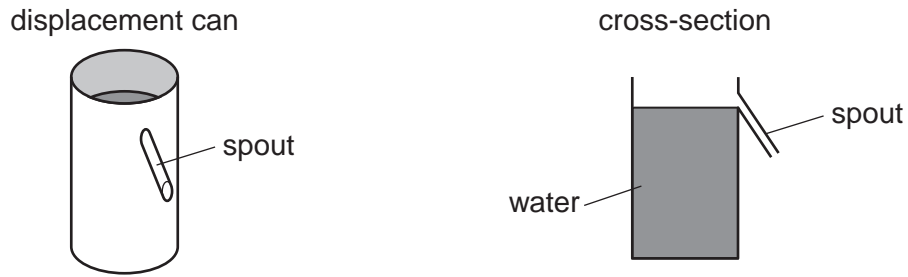

Fig. 2.1

The can is filled with water to the level of its spout.

(a) (i) Explain how the displacement can is used to measure the volume of an irregular object such as a glass stopper. State any additional apparatus that is required.

.....

.....

.....

.....[3]

(ii) State one possible difficulty in using a can that has

1. a very small diameter,

.....[1]

2. a spout that is attached near the bottom of the can.

.....[1]

(iii) Describe two precautions that will make the result more accurate.

1.

.....

2.

.....

[2]

(b) To determine the density of the glass, an additional quantity must be measured.

State

(i) the quantity to be measured,

.....[1]

(ii) the measuring instrument used.

.....[1]

- 3 A student investigates the frictional force on a block of wood sliding along a bench.

The block of wood has sides of length 15 cm by 10 cm by 5 cm and has a hook attached, as shown in Fig. 3.1.

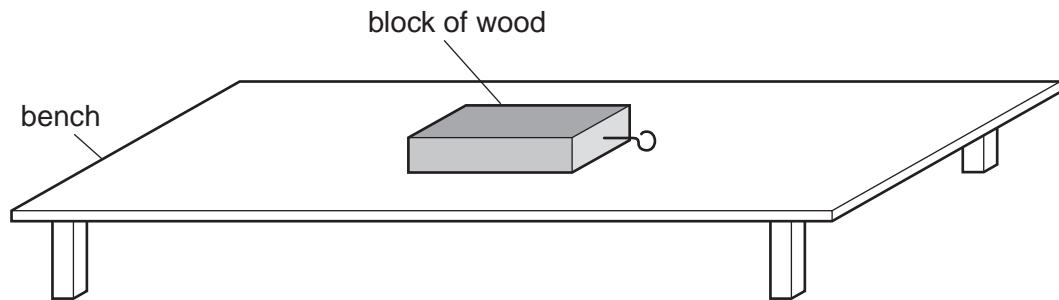

Fig. 3.1

Fig. 3.2 is a list of apparatus available to the student.

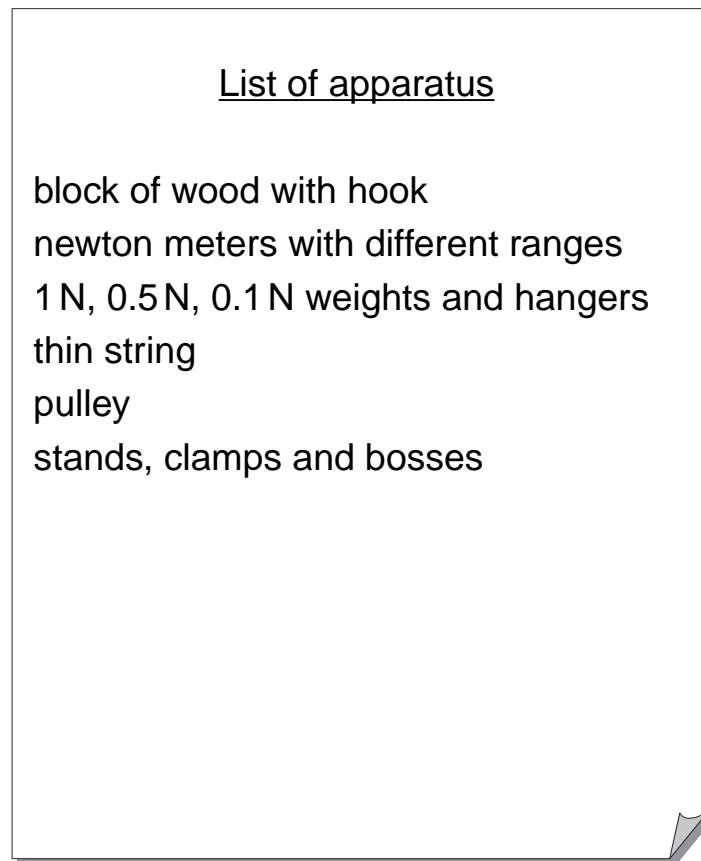

Fig. 3.2

(a) (i) The student measures the force needed to make the block of wood just start moving along the bench. Choosing apparatus from Fig. 3.2, describe a procedure that the student can use.

.....
.....
.....
.....
.....[2]

(ii) Describe one way to make the experiment more accurate.

.....
.....[1]

(b) The student now repeats the experiment, varying the surface area of the block of wood in contact with the bench. State how the student does this with the same block of wood.

.....
.....[1]

- (c) A teacher suggests that the frictional force F is related to the weight W of the block by the equation

$$F = kW$$

where k is a constant.

The student varies W by placing additional weights on top of the block and measures F .

- (i) On Fig. 3.3, write the headings in the table used to record the results.

Fig. 3.3

[1]

- (ii) Explain how the student can obtain the value of k using a graph of the results.

.....

.....

.....[2]

4 A student walks away from a street lamp at night and notices that his shadow changes.

The student investigates shadows in a darkened laboratory. He uses a lamp on a stand and a vertical card, as shown in Fig. 4.1.

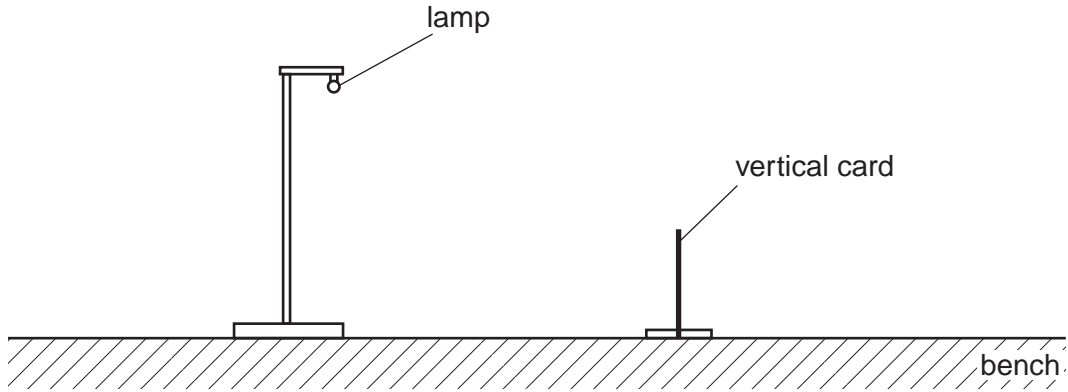

Fig. 4.1

(a) (i) On Fig. 4.1, draw a ray of light from the lamp to the bench, just passing over the top of the card. [1]

(ii) The region of the bench that does not receive light from the lamp is the 'shadow' of the card.
On Fig. 4.1, draw a line on the surface of the bench to indicate this shadow. [1]

(b) The card is moved along the bench **away from** the lamp.

State what happens to the shadow of the card.

.....

.....

.....[1]

(c) The shadow of the card produced in the laboratory is much darker than the shadow of the student in the street.

Suggest a reason for this.

.....

.....[1]

Permission to reproduce items where third-party owned material protected by copyright is included has been sought and cleared where possible. Every reasonable effort has been made by the publisher (UCLES) to trace copyright holders, but if any items requiring clearance have unwittingly been included, the publisher will be pleased to make amends at the earliest possible opportunity.

University of Cambridge International Examinations is part of the Cambridge Assessment Group. Cambridge Assessment is the brand name of University of Cambridge Local Examinations Syndicate (UCLES), which is itself a department of the University of Cambridge.