

UNIVERSITY OF CAMBRIDGE INTERNATIONAL EXAMINATIONS
General Certificate of Education Ordinary Level

PHYSICS

5054/01

Paper 1 Multiple Choice

May/June 2006

1 hour

Additional Materials: Multiple Choice Answer Sheet
Soft clean eraser
Soft pencil (type B or HB is recommended)

READ THESE INSTRUCTIONS FIRST

Write in soft pencil.

Do not use staples, paper clips, highlighters, glue or correction fluid.

Write your name, Centre number and candidate number on the Answer Sheet in the spaces provided unless this has been done for you.

There are **forty** questions on this paper. Answer **all** questions. For each question there are four possible answers **A, B, C** and **D**.

Choose the **one** you consider correct and record your choice in **soft pencil** on the separate Answer Sheet.

Read the instructions on the Answer Sheet very carefully.

Each correct answer will score one mark. A mark will not be deducted for a wrong answer.

Any rough working should be done in this booklet.

This document consists of **17** printed pages and **3** blank pages.



- 1 Which graph shows the motion of a heavy, steel ball falling from a height of 2 m?

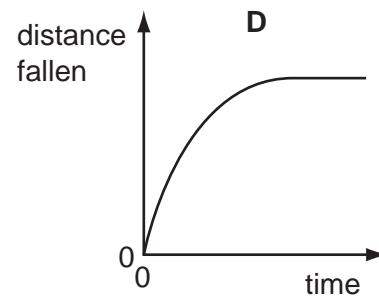
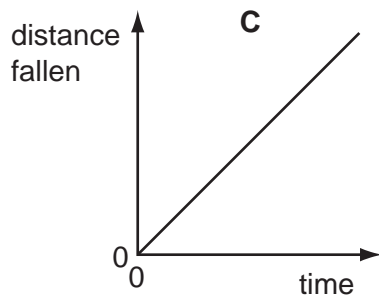
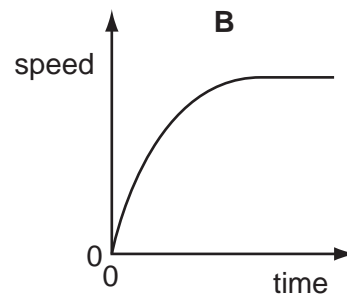
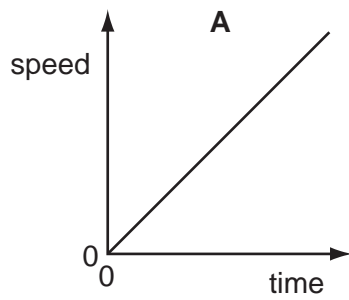

- 2 A force of 20 N pushes an object of mass 5.0 kg along a rough horizontal surface where the frictional force is 5.0 N.

What is the acceleration of the object?

- A** 1.0 m/s² **B** 2.0 m/s² **C** 3.0 m/s² **D** 4.0 m/s²
- 3 The diagram shows a vernier scale.

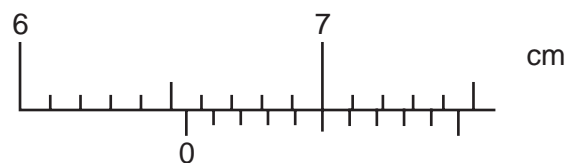

What is the reading on the vernier scale?

- A** 6.50 cm **B** 6.55 cm **C** 7.00 cm **D** 7.05 cm

- 4 Forces X and Y act on a block in the directions shown on the scale diagram.

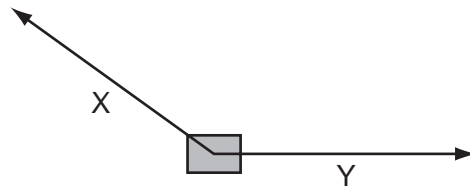

In which direction is the resultant force acting?

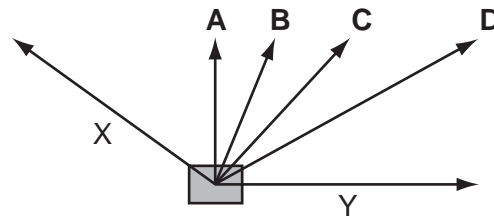

- 5 The diagram shows an aeroplane turning in a horizontal circle at constant speed.

In which direction is there a resultant force?

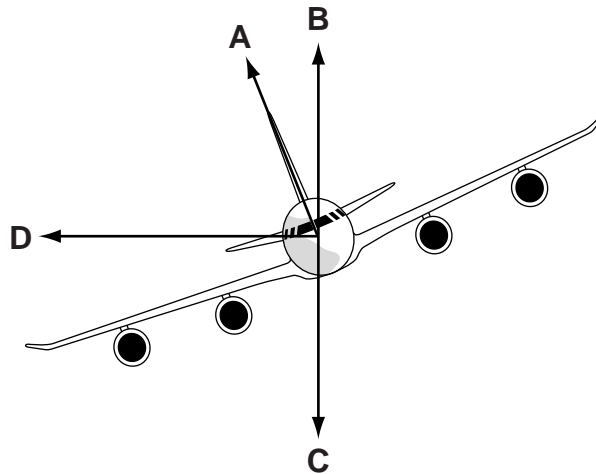

- 6 The inertia of a body is its resistance to changes in motion.

Which property is a measure of the body's inertia?

- A its density
- B its mass
- C the height of its sides
- D the size of its base

- 7 An object of mass 100 g is immersed in water as shown in the diagram.

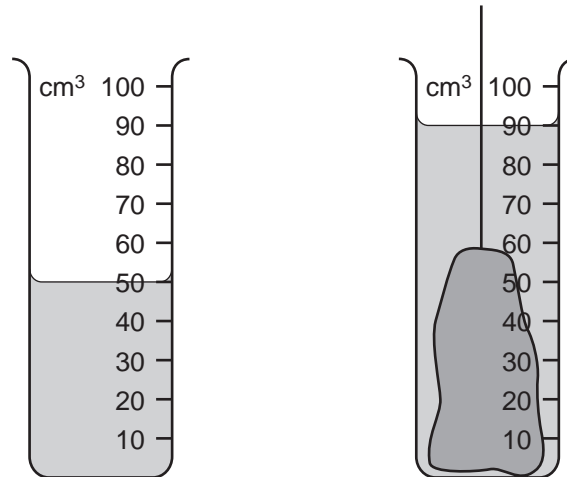

What is the density of the material from which the object is made?

- A 0.4 g/cm³
 B 0.9 g/cm³
 C 1.1 g/cm³
 D 2.5 g/cm³
- 8 If a nut and bolt are difficult to undo, it may be easier to turn the nut by using a longer spanner.
 This is because the longer spanner gives
- A a larger turning moment.
 B a smaller turning moment.
 C less friction.
 D more friction.
- 9 Some containers are made from thin glass.
 Which empty container is the **most** stable?

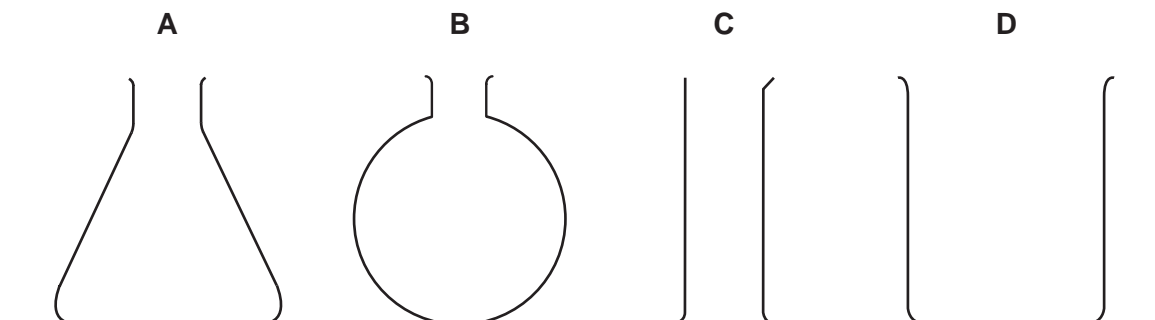

- 10 A metal wire, initially 1.000 m long, extends by 4 mm when a load of 2 N is added to it.

What will the length of the wire be if a further 3 N is added, assuming it does not extend beyond its limit of proportionality?

- A 1.060 m B 1.080 m C 1.010 m D 1.012 m

- 11 In a hydroelectric power station, water from a reservoir falls down a long pipe before entering the turbines. The turbines then turn the generator.

What is the **overall** energy conversion?

- A electrical energy into kinetic energy
B electrical energy into potential energy
C kinetic energy into chemical energy
D potential energy into electrical energy

- 12 Which statement about fission or fusion is correct?

- A During fission, hydrogen converts into helium and releases energy.
B During fission, uranium converts into daughter products and releases energy.
C During fusion, helium converts into hydrogen and releases energy.
D During fusion, uranium converts into daughter products and releases energy.

- 13 The input power to a motor is 300 W. In 20 s it lifts a load of 400 N through a height of 6.0 m.

What is the efficiency of the motor?

- A 12% B 25% C 40% D 75%

- 14 The diagrams show, to the same scale, the vertical sections of a set of circular vessels. Each vessel contains the same depth of water.

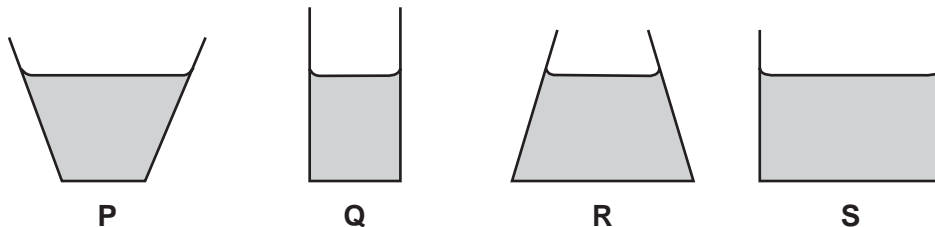

Which of the following statements is correct?

- A The water exerts the greatest pressure on the base of vessel P.
B The water exerts the greatest pressure on the base of vessel S.
C The water exerts the same force on the base of each vessel.
D The water exerts the same pressure on the base of each vessel.

- 15 Some of the more energetic molecules in a liquid leave the surface, leaving the rest of the liquid slightly cooler.

What is the name given to this process?

- A boiling
- B condensation
- C evaporation
- D freezing

- 16 A substance consists of particles that are close together and moving past each other at random. The average speed of the particles is gradually increasing.

What best describes the substance?

- A a gas being heated
- B a liquid being heated
- C a solid being heated
- D a solid being melted

- 17 Which thermometer is the best for measuring rapidly-changing temperatures?

- A a clinical thermometer
- B a liquid-in-glass thermometer
- C a thermocouple
- D all thermometers are equally good

- 18 Some ice cubes are taken from a deep-freeze and placed in a metal container. The container is heated at a constant rate and readings of temperature and time are taken. The results are recorded on a graph.

Which temperature corresponds to 0°C ?

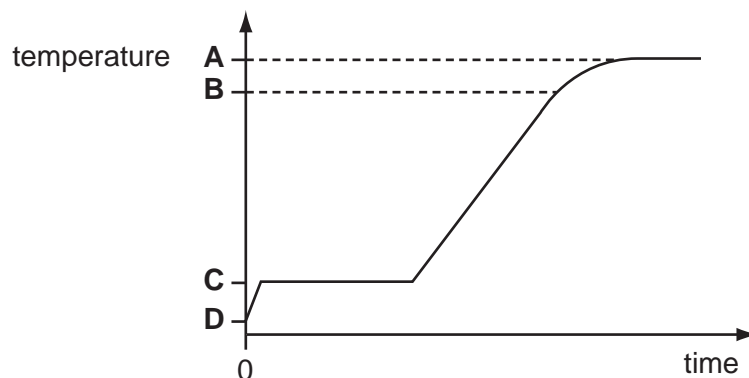

- 19 The diagrams show a bimetallic strip when it is at room temperature and after it has been cooled.



at room temperature

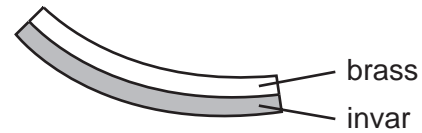

below room temperature

The change in shape occurs because

- A brass contracts more than invar.
 - B brass expands when it cools down.
 - C invar and brass contract by equal amounts.
 - D invar contracts more than brass.
- 20 Density changes are responsible for which method of thermal energy transfer?
- A conduction only
 - B convection only
 - C radiation only
 - D conduction, convection and radiation
- 21 In an experiment using a ripple tank, plane wavefronts arrive at a plane surface.

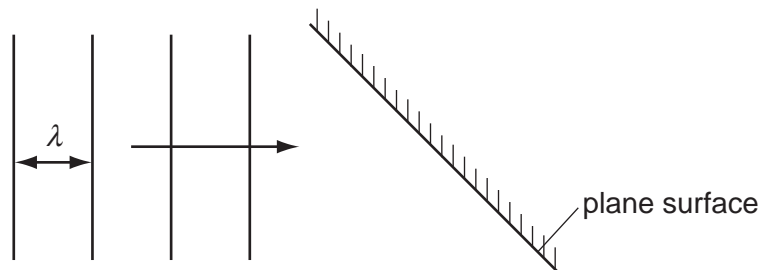

Which of the following correctly describes the waves after they are reflected from the surface?

	speed of waves	wavelength λ
A	faster	shorter
B	slower	longer
C	slower	shorter
D	the same	the same

22 Waves pass from deep water to shallow water and refraction occurs.

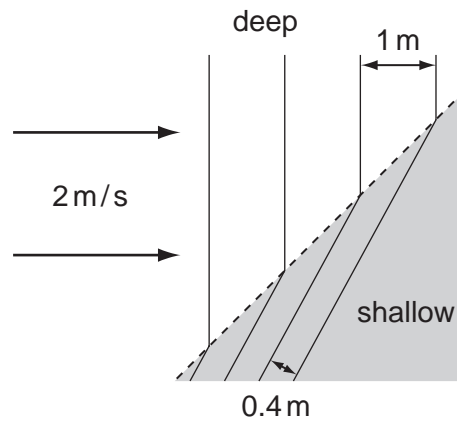

What is the speed of the waves in the shallow water?

- A** 0.2 m/s **B** 0.8 m/s **C** 2.0 m/s **D** 5.0 m/s

23 A lens forms a blurred image of an object on a screen.

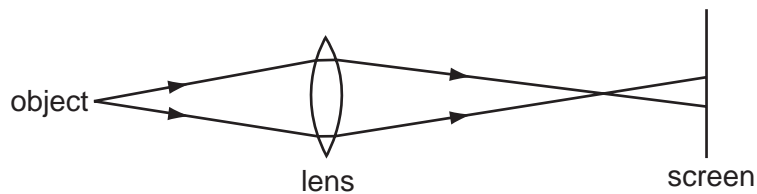

How can the image be focussed on the screen?

- A** by moving the object away from the lens and screen
B by moving the screen away from the lens and object
C by using a brighter object at the same position
D by using a lens of longer focal length at the same position

24 Light rays are deviated by a prism.

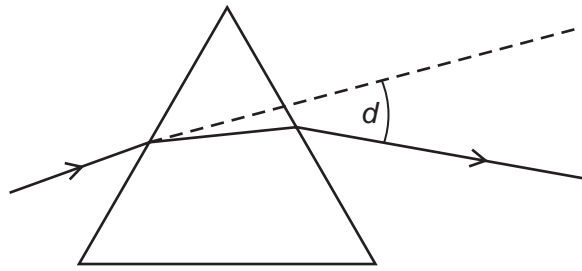

The deviation angle d is measured for light rays of different frequency, including blue light and red light.

Which graph is correct?

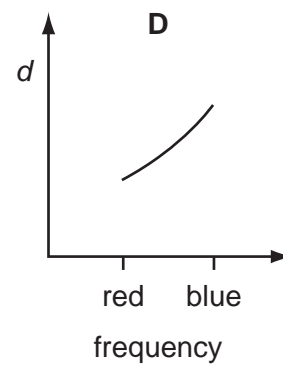
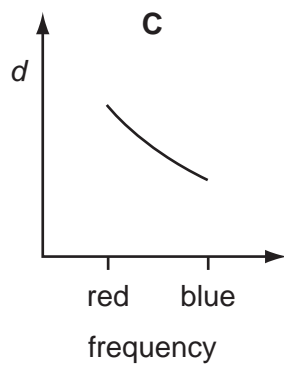
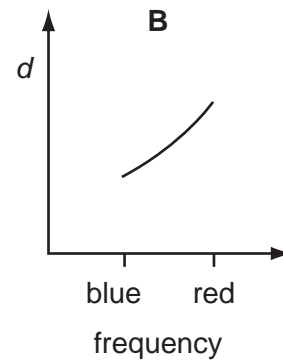
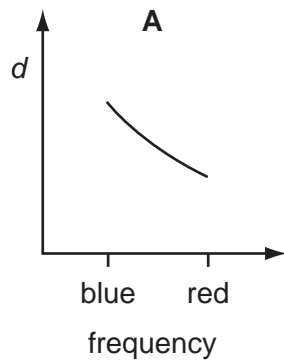

25 Which wave is part of the electromagnetic spectrum?

	speed m/s	type
A	330	longitudinal
B	330	transverse
C	3×10^8	longitudinal
D	3×10^8	transverse

- 26 A boy strikes a rigid metal fence with a stick to create a sound along the fence. A girl listens with her ear against the fence. One second after the fence is struck, the girl hears a sound through the air.

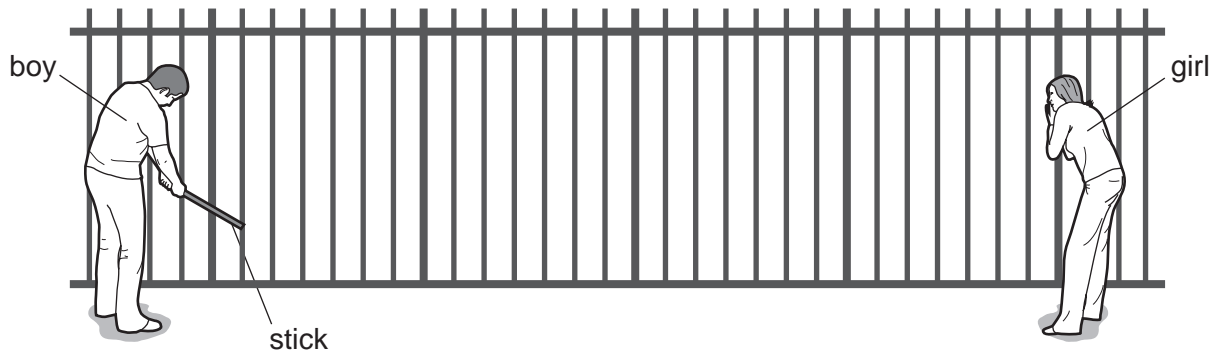

How long will it take for the sound to reach the girl through the fence?

- A 0 second
 - B less than 1 second
 - C 1 second
 - D more than 1 second
- 27 The diagrams show an iron nail in four different situations.

In which diagram will the nail become an induced magnet?

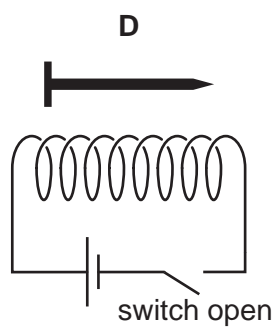
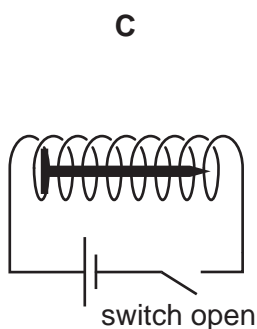
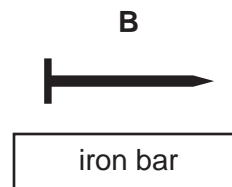
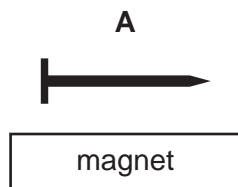

28 The diagram shows parts of a loudspeaker.

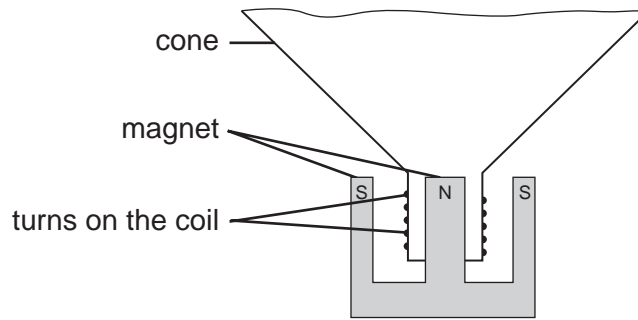

Which type of current is passed through the coil and why?

	current passed through coil	reason why
A	alternating	to keep the magnetic field constant
B	alternating	to make the coil vibrate
C	direct	to keep the magnetic field constant
D	direct	to make the coil vibrate

29 In an electrostatics experiment, a plastic rod is rubbed with a cloth. The cloth becomes negatively charged.

Which diagram shows the charge on the rod, and describes the movement of charge?

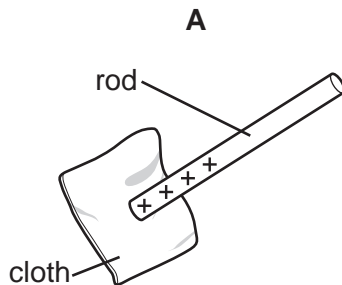

electrons move from the rod onto the cloth

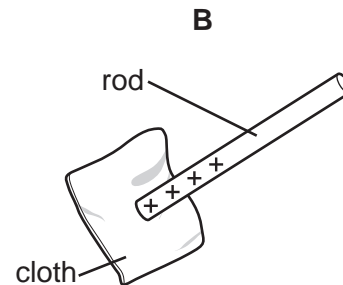

protons move from the cloth onto the rod

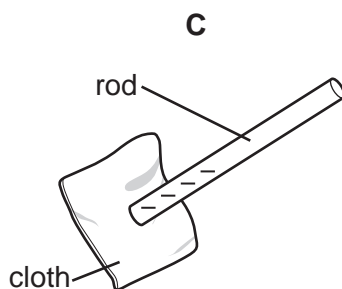

electrons move from the cloth onto the rod

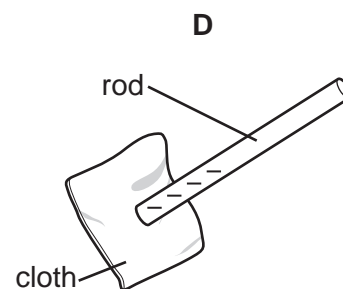

protons move from the rod onto the cloth

- 30 An electrical quantity is defined as ‘the energy converted by a source in driving a unit charge round a complete circuit.’

What is this quantity called?

- A current
- B electromotive force
- C potential difference
- D power

- 31 The diagram shows the current I /voltage V graph for a length of resistance wire.

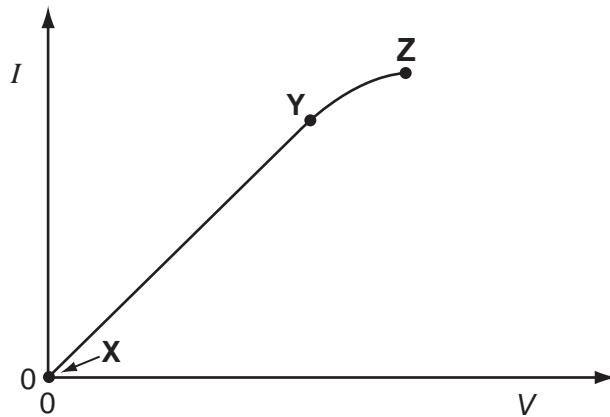

Where can Ohm's law be applied to the wire?

- A at Y only
- B at Z only
- C from X to Y
- D from X to Z

32 Diagram 1 shows a resistor connected to a battery, an ammeter and a voltmeter.

The ammeter reading is 0.5A and the voltmeter reading is 3.0V.

A second identical resistor is now connected in parallel with the first resistor, as shown in diagram 2.

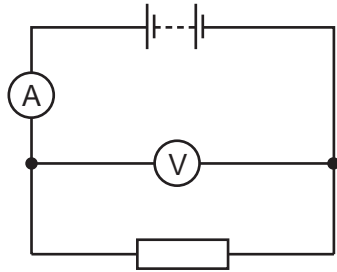

diagram 1

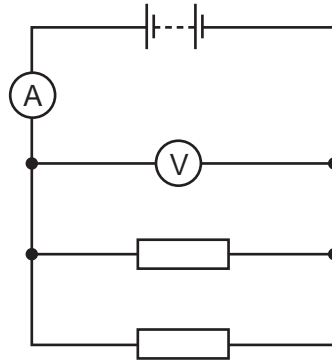

diagram 2

What are the ammeter and voltmeter readings in the circuit shown in diagram 2?

	ammeter reading / A	voltmeter reading / V
A	1.0	3.0
B	1.0	1.5
C	0.5	6.0
D	0.5	3.0

33 How much energy is converted in a resistor of 5.0Ω carrying a current of 2.0A for 10 seconds?

A 4.0J

B 25J

C 100J

D 200J

34 Two parallel wires carry currents in the same direction.

Which diagram shows the magnetic field around each wire and the direction of the force on each wire?

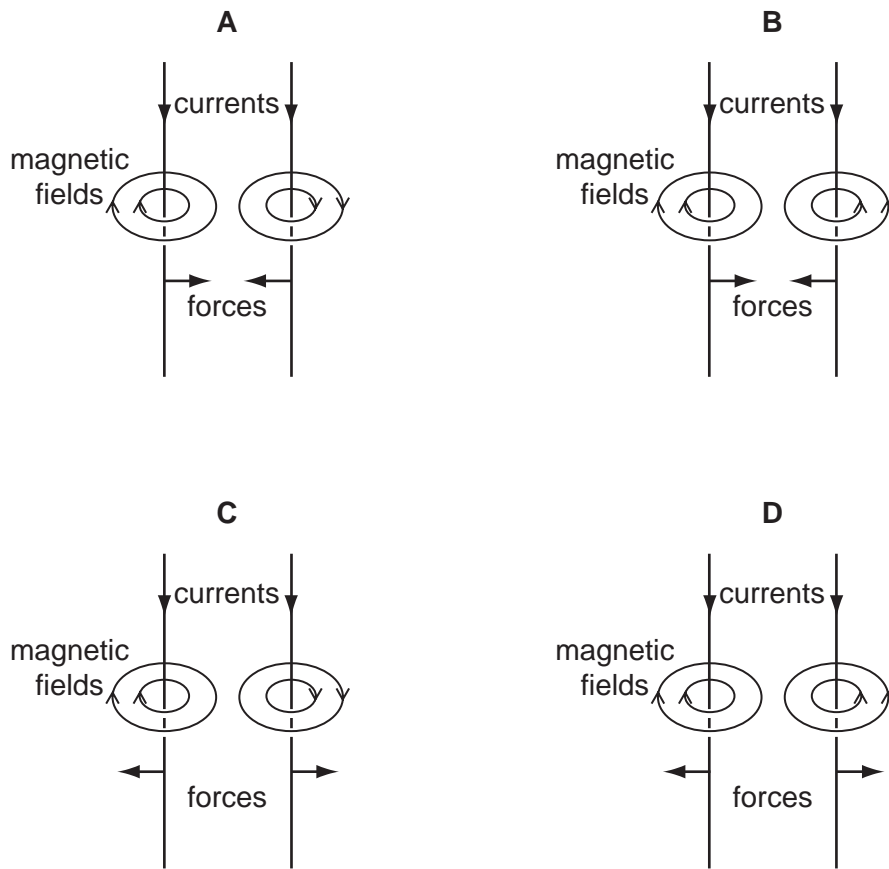

- 35 A permanent magnet moving up and down on the end of a spring induces an e.m.f. in a coil.

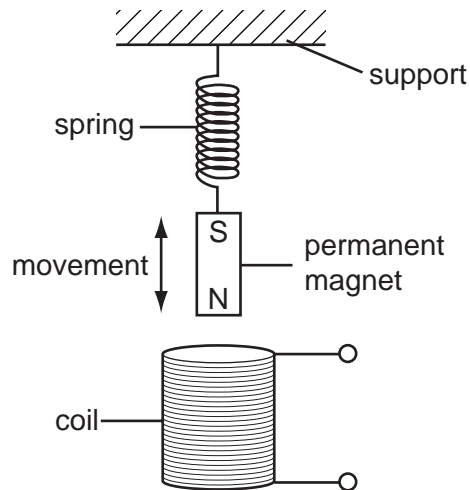

Which factor, on its own, would **decrease** the maximum value of the induced e.m.f.?

- A** increasing the number of turns in the coil
B increasing the strength of the magnet
C raising the coil
D raising the support of the spring
- 36 Why is a transformer used to connect a generator in a power station to a long distance transmission line?
- A** to decrease the voltage and decrease the current
B to decrease the voltage and increase the current
C to increase the voltage and decrease the current
D to increase the voltage and increase the current
- 37 The table shows part of the colour code for resistors.

black	brown	red	orange	yellow	green	blue	violet
0	1	2	3	4	5	6	7

Which resistor has a value of $4700\ \Omega$?

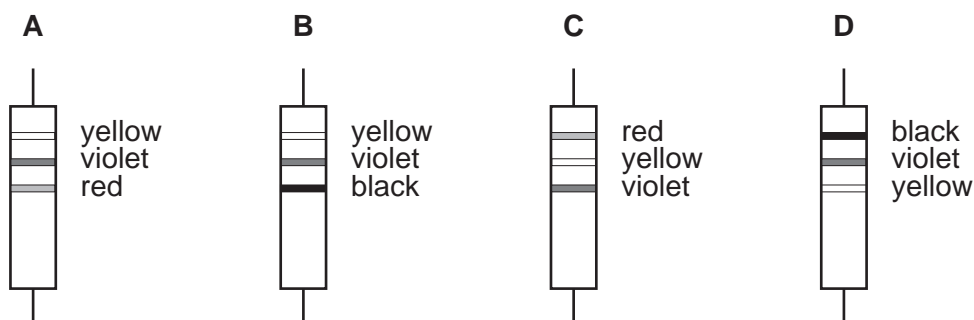

- 38 A student investigates the emission from an unknown radioactive source. The source is 10 cm in front of a detector. A strong magnetic field between the source and the detector is then switched on.

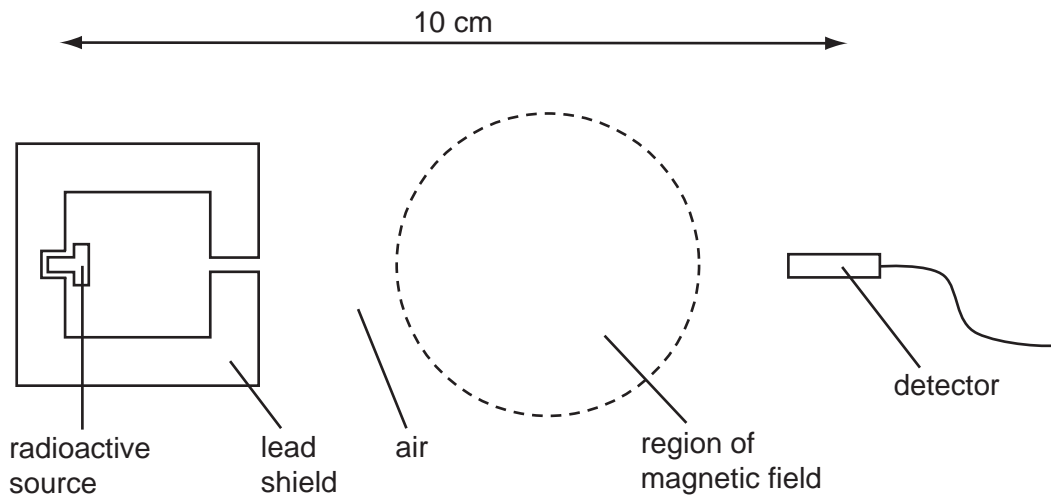

The results are shown.

	average count per minute
without magnetic field	4500
with magnetic field	2000
background radiation	50

Which radioactive source produced these results?

source	emissions from source
A	alpha-particles and gamma-rays only
B	beta-particles only
C	beta-particles and gamma-rays only
D	gamma-rays only

- 39 A detector is used to measure the count-rate near a radioactive source. The reading is 4000 counts per minute. After 30 minutes the count-rate has fallen to 500 counts per minute.

What is the half-life of the radioactive source? You may ignore the effects of background radiation.

- A** 3 minutes
- B** 5 minutes
- C** 6 minutes
- D** 10 minutes

- 40** Which conclusion can be drawn from the Geiger-Marsden alpha-particle scattering experiment?
- A** A positive charge is spread throughout the atom.
 - B** Electrons are arranged in orbits.
 - C** Electrons are negatively charged.
 - D** There is a dense nucleus in the atom.

BLANK PAGE

Permission to reproduce items where third party owned material protected by copyright is included has been sought and cleared where possible. Every reasonable effort has been made by the publisher (UCLES) to trace copyright holders, but if any items requiring clearance have unwittingly been included, the publisher will be pleased to make amends at the earliest possible opportunity.

University of Cambridge International Examinations is part of the University of Cambridge Local Examinations Syndicate (UCLES), which is itself a department of the University of Cambridge.